



CMR Electrical Ltd  
Bolton House  
Five Chimneys Lane  
Hadlow Down  
East Sussex  
TN22 4DX  
Tel: 01825 733600

# LD4-2 & LD4-2V

## 3 and 4 Zone Water Detection Alarm

### Installation and Operation Manual



# Contents

- 1) *Display and Control*
- 2) *Operation*
- 3) *Water leak detected Alarm Test*
- 4) *Water Detected Alarm*
- 5) *Sensor Fault*
- 6) *Water Detection Sensitivity Adjustment*
- 7) *Installation*
- 8) *Positioning the water detection cable*
- 9) *Fitting Cable clips*
- 10) *Water Shutdown Valve*
- 11) *Water Shutdown Valve Override Procedure*
- 12) *Beacon and beacon sounder*
- 13) *Fitting an SMS /Email messaging system*
- 14) *Fitting the battery backup*
- 15) *Commissioning*
- 16) *Maintenance*
- 17) *Fault Diagnosis*
- 18) *Installation Drawing*
- 19) *Housing Size*

## 1) Display and Control

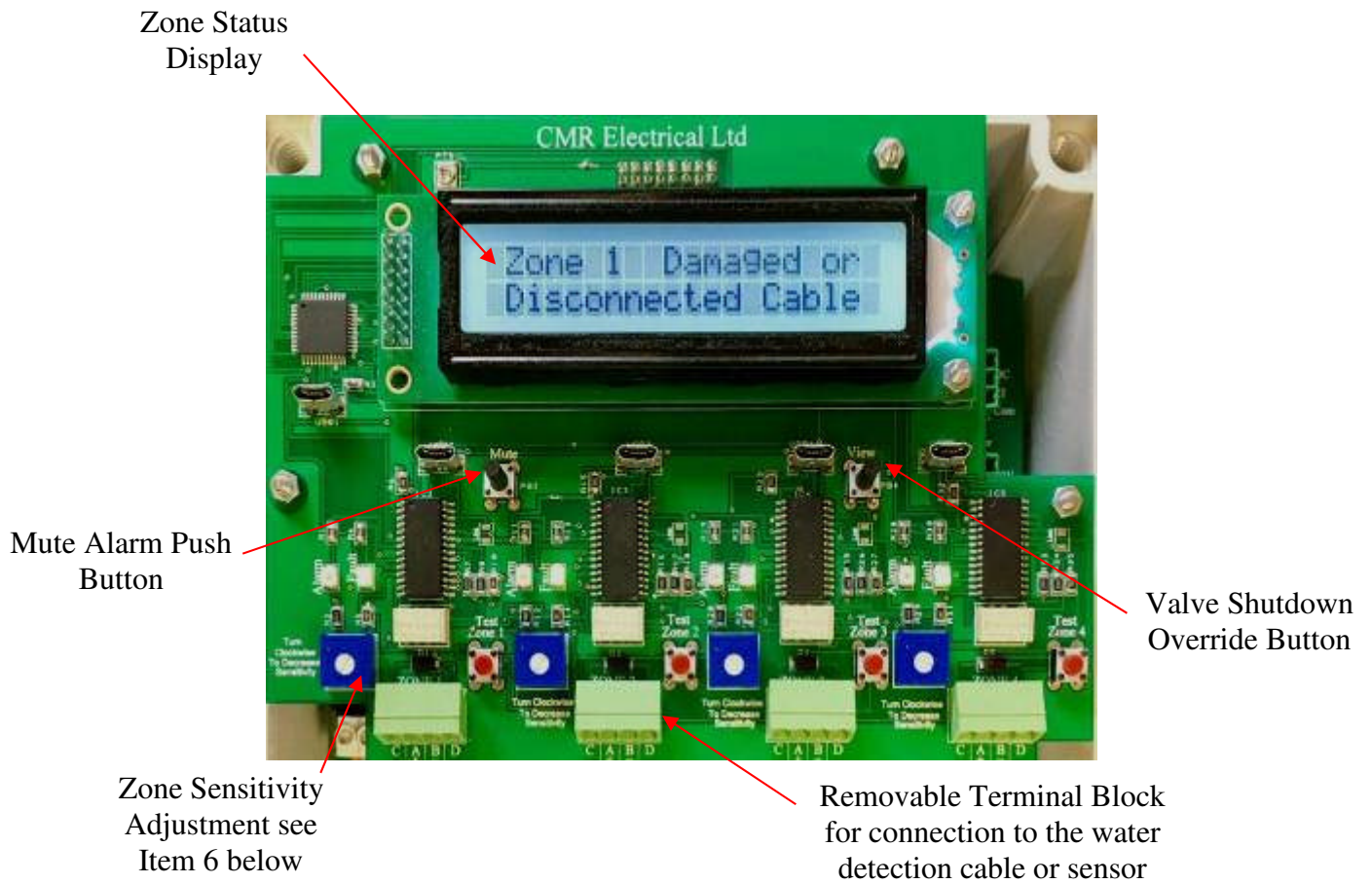

### Display Screens



All detection cables or sensors are connected correctly and a water leak has not detected



The detection cable or sensor has been disconnected, unplugged, damaged or cut



A water leak has been detected in the detection cable or sensor

## 2) Operation

In normal operation with no alarms or faults, the audible warning device will be OFF and the display will be showing “The System has no Alarms or Faults”. If one or more of the zones has a disconnected or damaged cable, the audible warning device will sound and the display will show “ Zone (1-2-3-4) Damaged or Disconnected Cable”. If the detection cable or sensor detects water, the audible warning device will sound and the display will show “Water Leak Detected at Zone (1-2-3-4)”. If water shutoff valves are fitted, and a zone detects water, the appropriate valve will close and the appropriate internal “Closed” lamp will illuminate. The system will automatically open the valve allowing water to flow once more providing the “Mute” button has been operated to acknowledge the alarm, the water leak has been cleared up and the detection cabled dried out. This shutdown can be overridden, See Item 11 below. If the system has multiple alarms, the screen will automatically scroll between each alarm one after the other providing the current alarm has been muted. This scrolling can be stopped at any time by continually pressing the “Mute” push button. If multiple alarms occur at the same time, each alarm will need acknowledging by the press of the “Mute” button. i.e. zones 1 & 2 go into water detected alarm at the same time, the audible warning will be going with “Zone 1 water detected” on display. Pressing “Mute” will stop the audible warning but it will immediately start again only this time the display will be showing “Zone 2 water detected”. This second alarm will also need the “mute” button operated to silence the audible warning. For ease of installation and fault diagnoses both individual zone “Alarm” and “Fault” lamps have been provided internally on the top PCB.

## 3) Water leak detected Alarm Test

To test that the unit is functioning correctly, pressing the red “Test Zone” button to put the system into a Water detected alarm. Using the test facility will operate the alarm relays generating a BMS alarm, activation of the remote beacon/sounder if fitted and on the LD4-2V systems, close the water shutoff valve.

## 4) Water Detected Alarm

When the detection cable comes into contact with water anywhere along its length, the audible warning device will start, the common alarm and if fitted, the zone alarm relay will close and the display will show the zone number. To stop the audible warning press the “Mute Alarm” button. The system will remain in this state until the water has been removed from the cable when the alarm relay will automatically turn OFF.

## 5) Sensor Fault

Because of the exposure of the detection cable on the floor, the system monitors for any breaks in the detection cable including the interconnection cable between the control unit and the detection cable. If a break within the cable is found, the audible warning device will start, the fault relay will operate and the display will show the zone number. To stop the audible warning press the “Mute Alarm” push button. The system will remain in this state until the sensor fault is repaired when the display and common fault relay will revert back to normal. If the controller detects a break in the cable, the system will continue to detect water up to the point of the break.

## 6) Water Detection Sensitivity Adjustment

To increase the sensitivity of the cable turn the potentiometer ANTICLOCKWISE, to de-crease the sensitivity turn CLOCKWISE.



Increase Sensitivity



Decrease Sensitivity

**7) Installation**

**THIS EQUIPMENT SHOULD ONLY BE CONNECTED AND WORKED ON BY A QUALIFIED ELECTRICIAN.**

To mount the unit to a wall, first remove the front cover to expose the internal equipment. In each corner of the housing positioned below/above the front cover fixings will be found the mounting holes.

Plastic glands have been provided for incoming power and outgoing signal cables. The large gland requiring a 20mm hole within the housing is for the power cable and the smaller gland requiring a 13mm hole within the housing is for the signal cable. Care should be taken when drilling the holes to ensure no damage occurs to the electronic equipment.

A suitably rated 230VAC power cable supply should be run from a fused spur to the unit and terminated to the internal terminal block marked “L”, “E” & “N”. The fuse within the fused spur should be rated at 5 Amps.

**Connections within the Alarm Housing**

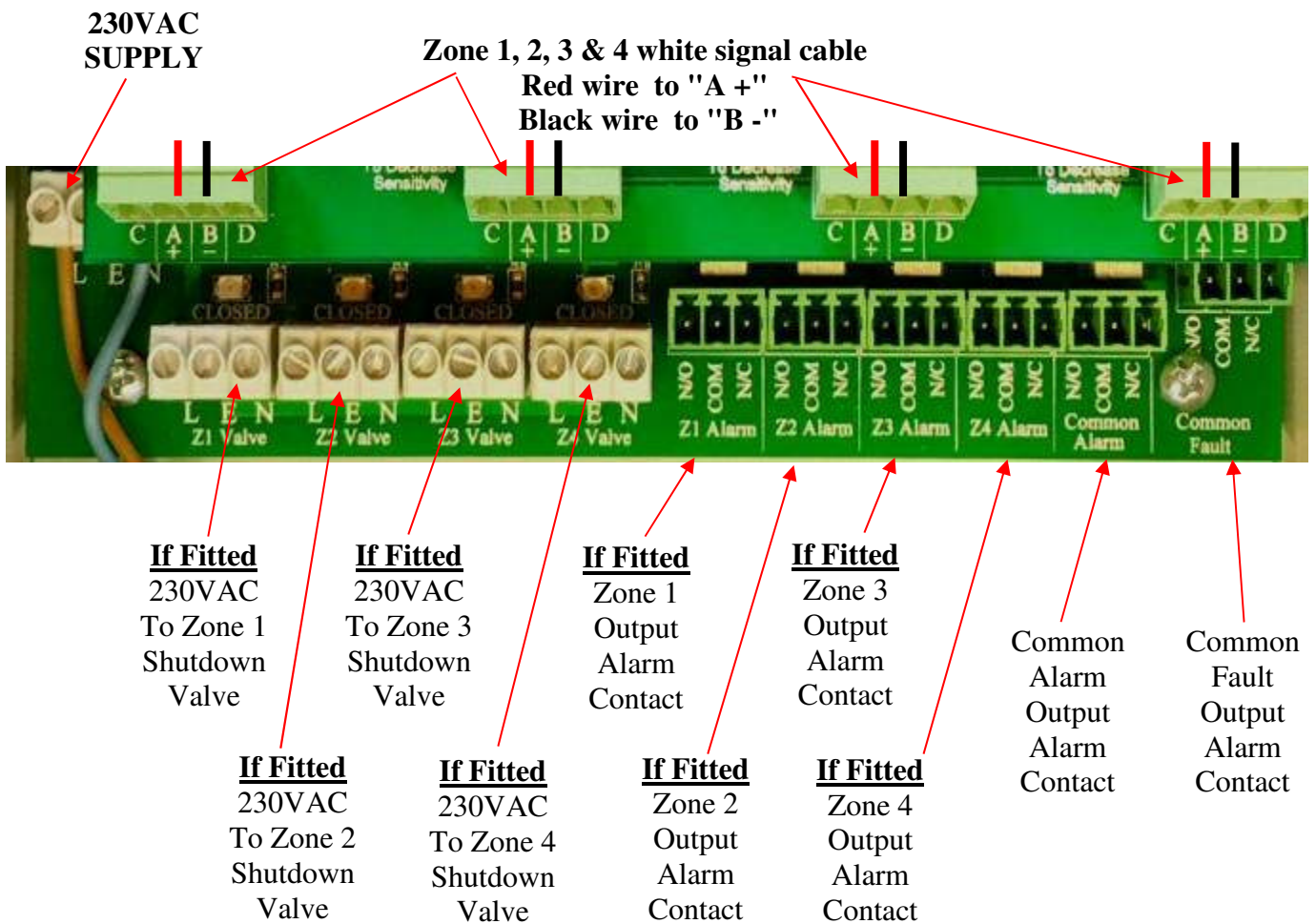

**Output Volt Free contacts for use by a Building Management System.**

<i>Function Required</i>	<i>Fitted as Standard</i>	<i>Relay Output Terminals</i>
Zone 1 alarm	No	Z1 Alarm
Zone 2 alarm	No	Z2 Alarm
Zone 3 alarm	No	Z3 Alarm
Zone 4 alarm	No	Z4 Alarm
Water detected alarm any zone	Yes	Common Alarm
Cable Disconnected Alarm	Yes	Common Fault
Power Fault	Yes	Common Fault

All Zone wiring and volt free alarm / fault relays wiring is to removable screw type terminal blocks.

## Connection of the Signal cable, Water detection cable & End Of Line Terminator

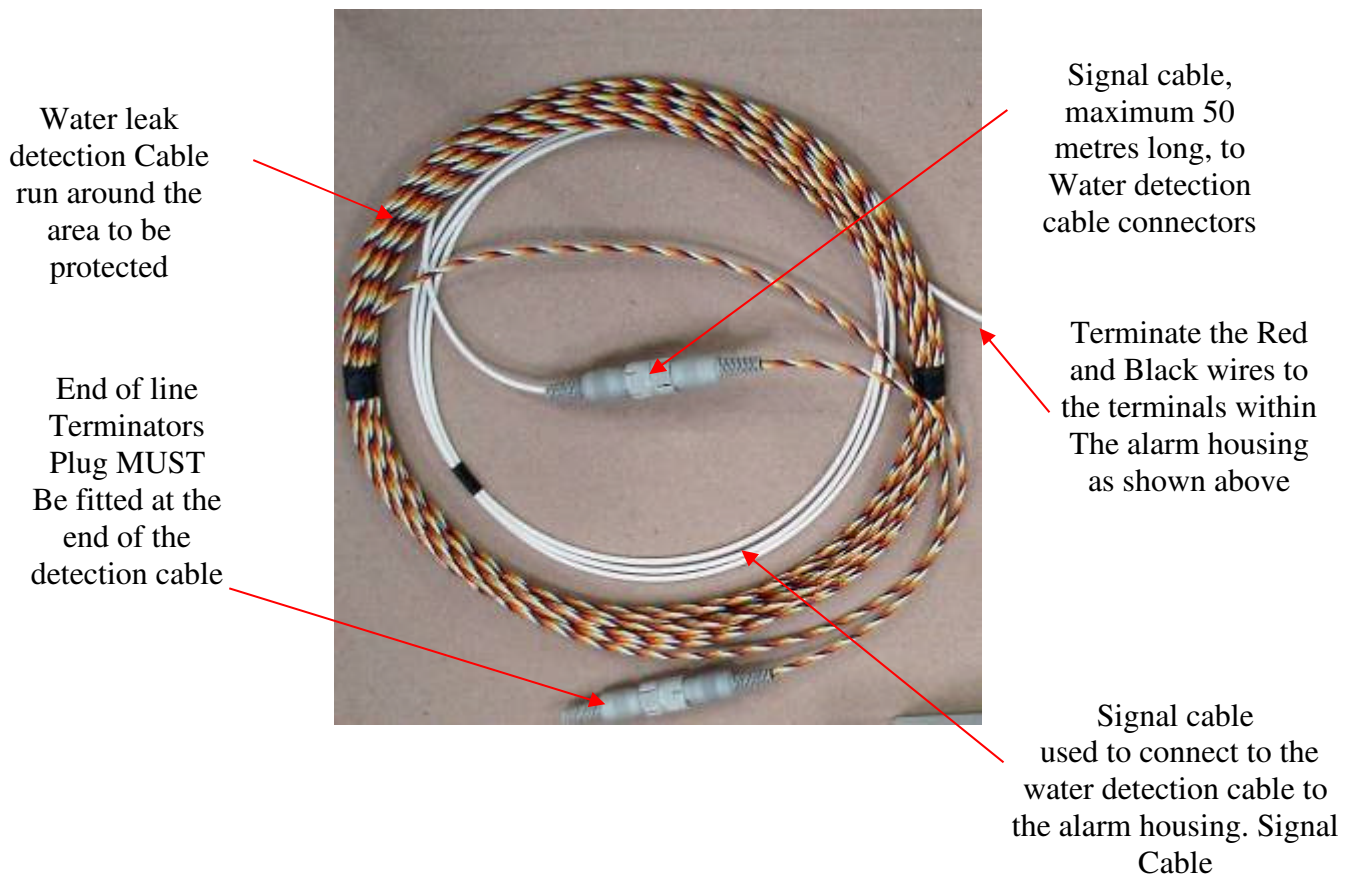

### 8) Positioning the water detection cable

The detection cable is susceptible to damage and should not be fitted to areas where the cable is likely to be damaged or walked on. If fitting the cable around Air Conditioning Units with humidifiers, ensure that cable is positioned at least one metre from the ACU to stop intermittent alarms being generated from over humidity or water droplets from the AHU. Having positioned the detection cable, ensure that the End of line terminator is plugged into the end of the cable (see drawing above).

### 9) Fitting Cable Clips

If Cable Clips are required, to protect the small sensor wires and to stop false water detected alarms from occurring insulating tape should be first applied around the detection cable before the clip tongue is closed. Clips should be fitted approximately every 1 to 1.5 metres apart. When using clips make sure that the cable touches the floor between the clips, **DO NOT** tighten the cable so that the cable does not touch the floor.

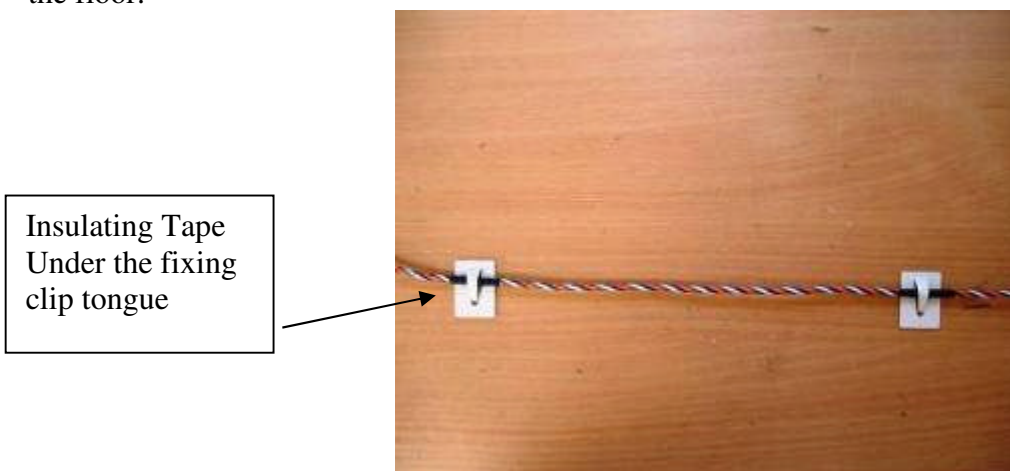

### 10) Water Shutdown Valve

If the system is supplied with water shutoff valves, once a water leak has been detected the unit will remove the 230V supply holding open the valve thereby closing it and stopping the flow of water. Once the leak has been rectified the detection cable may take some hours to dry out. During the dry out period the valve can be opened and closed using the procedure outlined in *Item 11* below.

#### Connection of Water Shutdown Ball Valve

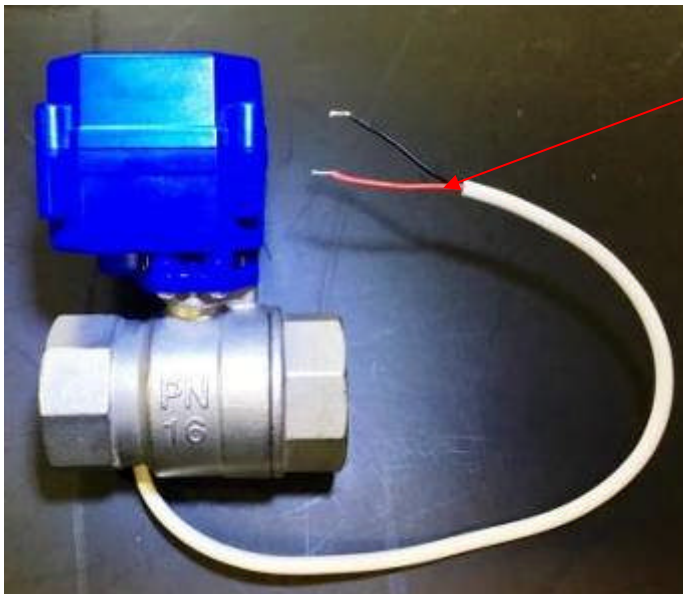

The 230VAC supply to the valves is generated from within the alarm unit. 15 to 25mm valves are supplied with a red and black cable whilst larger valves are red and green. For good practice connect live to the red wire and neutral to the black or green wire.

The Valve is supplied with a short length of cable that will need extending back to the Valve terminals within the alarm unit.

**WARNING, In order to shut properly, this type of valve need powering for at least 3 minutes.**

#### Connection of Water Shutdown Solenoid Valve



The 230VAC supply to the valves is generated from within the alarm unit.

Having removed and opened the 3 pin socket, connect live to terminal "1", neutral to terminal "2" and Earth to the earth terminal

#### **PLEASE NOTE;**

**The type of valve MUST be fitted with the arrow on its body facing the direction of flow, if not, the valve will not stop the flow of water.**

**11) Water Shutdown Valve Override Procedure**

This feature will only work if there is a current water leak detected alarm, the zone has not already been overridden and the alarm has been Muted. To put the system into shutdown override and re-open the water valve, press and keep pressed the “Shutdown Override” push button. On pressing the button the unit will start beeping. Keeping the finger on the button and wait until the beeping to stops. Once this happens stop pressing the button. The system will automatically cancel the override once the zone stops detecting a water leak. If the Override needs cancelling and the valve needs to be closed again, Press the “Shutdown Override” button again and following the same procedure will cancel the override and close the shutdown valve.

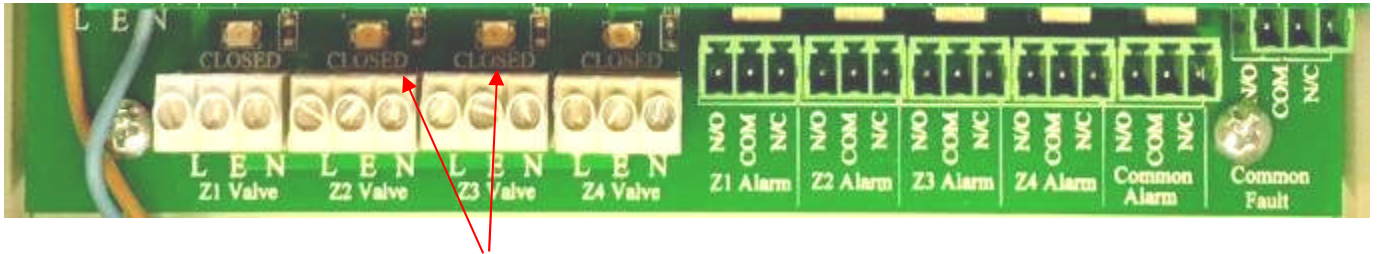

Zone 1-2-3 & 4 Shutdown valve closed lamps

**12) Beacon and beacon sounder**

If a beacon or beacon sounder is supplied connect to the three terminals identified as “Sounder Beacon” as follows.



Sounder Beacon terminal block

**12a) Non Mutable Beacon or beacon sounder**

If the beacon or the beacon sounder is to be active (On all the time) until the water leak alarm has cleared, connect as follows

Terminal reference	Connect Beacon / beacon sounder terminals to the following terminals
+V	Beacon +V or Strobe /Tone + terminal
BOV	Beacon -V or Strobe /Tone - terminal
SOV	NO connection to this terminal

**12b) Mutable Beacon or beacon sounder**

If the beacon or the beacon sounder is to turn off when the “Mute” push button is pressed connect as follows.

Terminal reference	Connect Beacon / beacon sounder terminals to the following terminals
+V	Beacon +V or Strobe /Tone + terminal
BOV	NO connection to this terminal
SOV	Beacon -V or Strobe /Tone - terminal



### 12c) Mutable sounder Beacon on all the time

If the beacon is to remain alight all the time an alarm is current but the sounder is to be turned off when the “Mute” push button is pressed connect as follows.

Terminal reference	Connect Beacon / beacon sounder terminals to the following terminals
+V	Strobe and Tone + terminal
BOV	Strobe - terminal
SOV	Tone - terminal

**Warning; if the above option “12c” is required, remove the electrical link connected between the second (Strobe -) & third terminals (Tone -) terminals within the sounder.**

### 13) Fitting an SMS / Email messaging system



Use the “Text” terminal block

LD4-2 Terminal No.	Cable wire colours fitted to the messaging system
DC	<b>RED</b>
Z1	<b>BLUE</b>
COM	<b>BLACK</b>

### 14 Fitting the battery backup

The battery should be fitted connected after the system as been commissioned. Place the battery within the housing in the space provided. Connect the small BLACK cable to the “—“ battery terminal and the RED with black dots wire to the batteries “+” terminal. If the battery is misconnected, the battery fuse located on the small PCB will blow.

### 15 Commissioning

Having connected the unit as described above, turn of the mains power to the unit. The display should show “The System has No Alarm or Faults” If not, refer to the “Fault Diagnostics” below. If the unit powers up with the audible warning going, press the mute button and wait to see if the alarm clears. If the alarm remains after approximately 20 seconds , refer to the “Fault Diagnostics” below. With the unit powered, unplug the End of line terminator positioned at the end of the detection cable. The controller should display “Zone (1-2-3-4) Damaged or Disconnected Cable” and the audible warning device should sound, if not refer to the “Fault Diagnostics” below, press the “Mute” button, the audible warning device should stop. Replace the End of line terminator to return the system to normal. Using a cup of CLEAN water, immerse a small area (50mm long) of cable into the water. The controller should display “Water Leak Detected ZONE (1-2-3-4)” and the audible warning device should sound, if not refer to the “Fault Diagnostics” below. Press the “Mute” button the audible warning device should stop. Remove the water and wipe the cable with some tissue paper. Repeat for all other zones.

### 16) Maintenance

The system should be fully tested using the commissioning procedure at least once a year for correct operation and if fitted, a check made to ensure that the shutoff valve operates correctly. All cables should be inspected at the same time for signs of damage, dirt contamination or mis-placement.

## 17 Fault Diagnoses

<b>Fault</b>	<b>Possible Reason</b>
Display is OFF and the unit appears dead	<ol style="list-style-type: none"> <li>1) No power to the control unit. <i>Test with a meter</i></li> <li>2) The power fuse has blown. <i>Test the fuse with a meter</i></li> </ol>
The Water Detected statement remains in the screen all the time.	<ol style="list-style-type: none"> <li>1) The cable needs drying out after detecting water. <i>Using tissue paper dry the cable.</i></li> <li>2) The cable has a short between the sensors due to Contaminants. <i>Clean the cable using water and tissue paper dry out afterwards</i></li> <li>3) The cable has been damaged. <i>Visually check the cable for damage.</i></li> <li>4) The sensitivity of the detection system is too sensitive. <i>Remove the lid from the small plastic box connected to the detection cable and turn the potentiometer until the system resets.</i></li> <li>5) System fault. <i>Return to manufacture</i></li> </ol>
The display appears dead and does not show “Water Detected” even though the system has a water detected alarm and the audible warning device is sounding.	<ol style="list-style-type: none"> <li>1) System fault. <i>Return to manufacture</i></li> </ol>
The system will not record a water detected alarm, the Display and audible warning device do not react to water on the cable.	<ol style="list-style-type: none"> <li>1) Sensitivity could be too low or a Possible system fault. <i>Remove the lid from the small plastic box connected to the detection cable and turn the potentiometer until the system goes into alarm.</i></li> <li>2) System fault. <i>Return to manufacture</i></li> </ol>
The display shows faulty or disconnected cable all the time.	<ol style="list-style-type: none"> <li>1) The detection or signal cable is broken or disconnected. <i>Check for cable faults or breaks.</i></li> <li>2) Detection module fault. <i>Dip part of the detection cable into a cup of water and see if it sets up an alarm.</i></li> <li>3) Controller fault. <i>Press the test button to setup an alarm.</i></li> <li>4) System fault. <i>Return to manufacture</i></li> </ol>
Horn not working	<ol style="list-style-type: none"> <li>1) System fault. <i>Return to manufacture</i></li> <li>2)</li> </ol>
The battery will not power the system	<ol style="list-style-type: none"> <li>1) Battery discharged, disconnect a lead and test with meter.</li> <li>2) Battery fuse blow, see item 10</li> <li>3) Charger fault, disconnect a battery lead &amp; check for 13.5V</li> </ol>



To help with fault diagnoses individual “Alarm” and “Fault” lamps are provided so show the status of each zone.

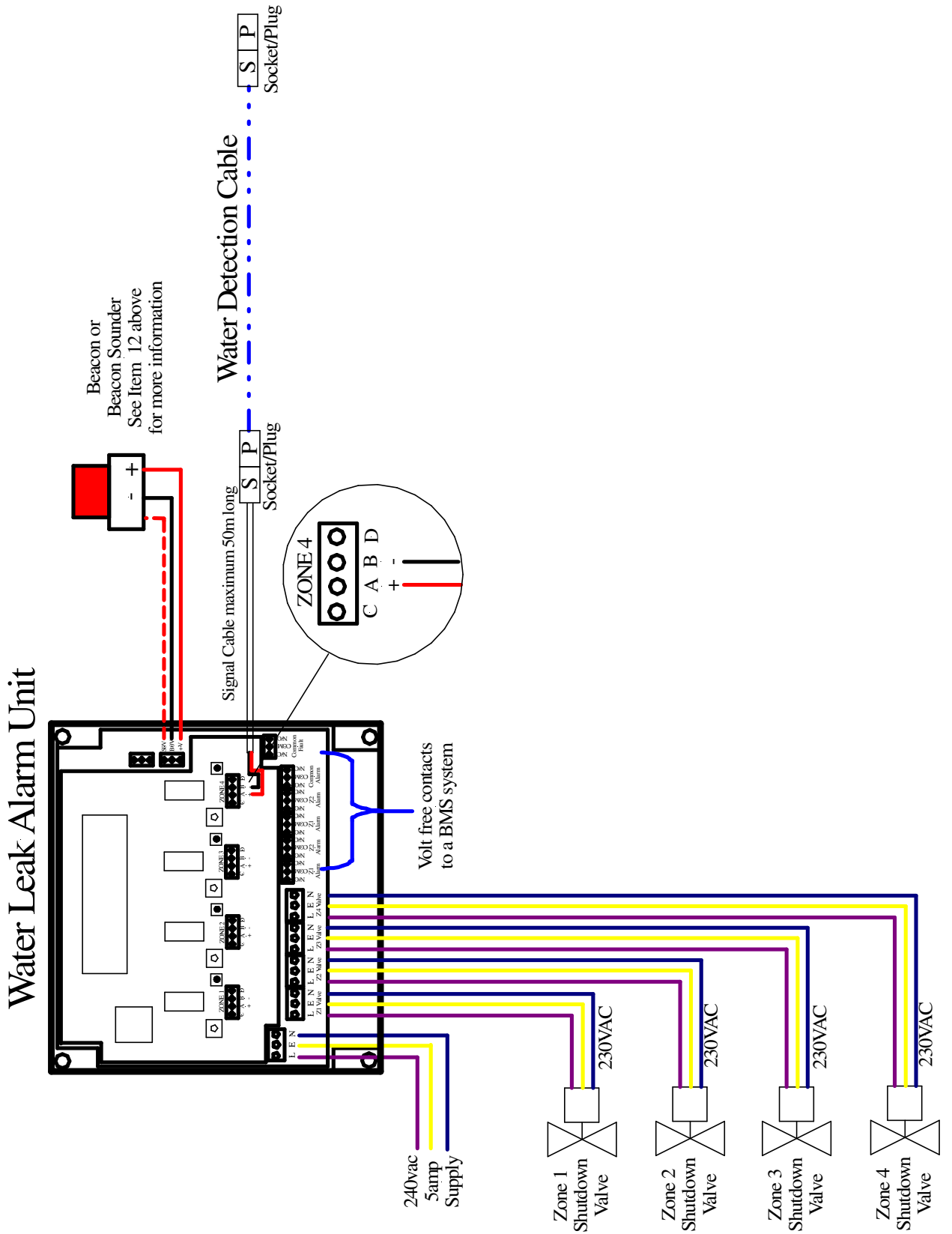

System using Water Detection Cable. Not all the shown devices may be available on your system

19 Housing Sizes

**Main control unit and Outstation type OS4V**

